

2/2 way solenoid valve normally closed or normally open

type 62, body stainless steel 1.4301 (AISI304)

pilot operated, DN 13-50mm, G1/2 – G2

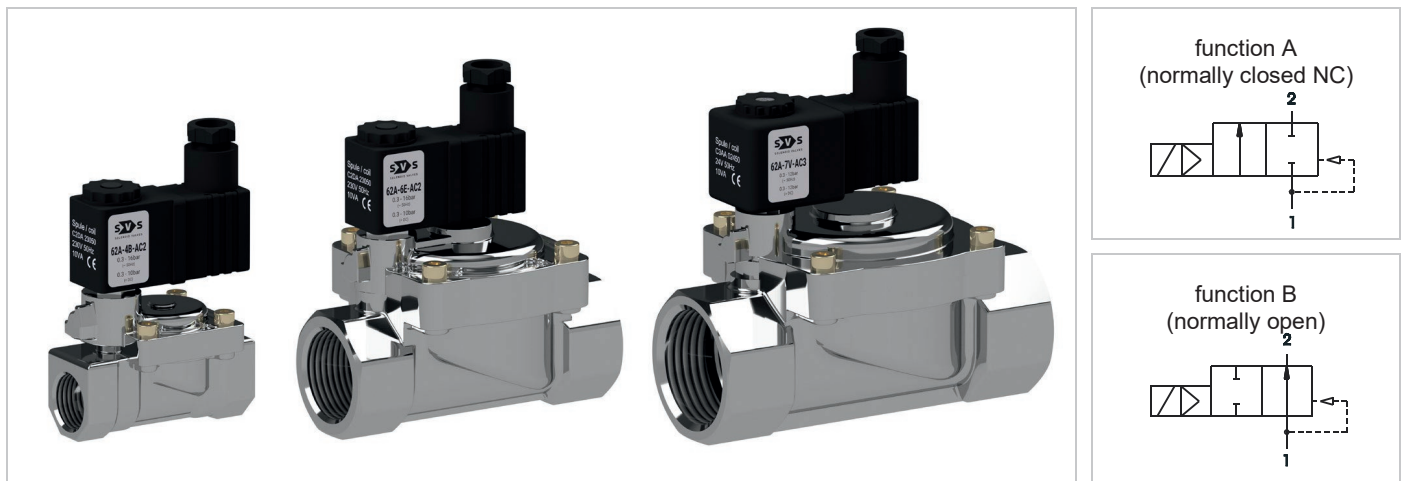

SPECIFICATION	
General	
type of construction	2/2-poppet valve, with diaphragm, normally closed NC or normally open NO, coil 360° rotatable
operator	solenoid
ports	G1/2 – G2
ambient temperature	-20 °C to +50 °C, higher allowed ambient temperatures on request
fluid temperature	dependent on sealing material and coil
viscosity	max. 21mm ² /s (cst) or 3°E
material	body and inner parts stainless steel 1.4301 (AISI 304), 1.4305 (AISI 303) and 1.4105IL (AISI 430 FR), sealing see type selection
mounting	installation into fixed piping system
installation	in any position, preferable vertical fixed solenoid coil
unit of supply	without connector
electrical data	
voltage	DC voltage or AC voltage
standard voltage	24V DC, 24V AC, 230V AC
special voltage on request	6V-200V DC, 12V-240V, 50Hz or 60Hz
acceptable voltage tolerance	+/- 10%
power consumption	see specifications at solenoid coils
coil type	temperature class F (155°C), winding class H (180°C)
duty cycle	100% ED (DB), continuous operation
protection class	IP65 according DIN EN 60529 (DIN 40050) with correctly mounted connector
pneumatic – hydraulic	
flow medium	all liquids and gases, which don't attack the used material
max. body housing pressure	G1/2 to G1 PN 20 (bar), above PN 16 (bar)
response time	depending on operating pressure and fluid
certificate	
special equipment on request	coil type with cable, coils for temperature class H (180°C), manual override

2/2 way solenoid valve normally closed or normally open

type 62, body stainless steel 1.4301 (AISI304)

pilot operated, DN 13-50mm, G1/2 – G2

type 62A, normally closed									
type * (order-nr.)	NW DN (mm)	ports	maximum differential pressure in bar **						kv-value (m ³ /h)
			coil C2DA		coil C3AA		coil CWMA ***		
			~ (AC)	= (DC)	~ (AC)	= (DC)	~ (AC)	= (DC)	
62A – 4. – AC...	13	G1/2							3,4
62A – 5. – AC...	19	G3/4	0,3 – 16	0,3 – 10	0,3 – 16	0,3 – 16	0,3 – 10	0,3 – 8	4,8
62A – 6. – AC...	24	G1							8,5
62A – 7. – AC...	30	G 1 1/4							15
62A – 8. – AC...	38	G 1 1/2	0,3 – 12	0,3 – 8	0,3 – 12	0,3 – 12	0,3 – 8	0,3 – 6	19,5
62A – 9. – AC...	48	G 2							30,5

* Type designation (order-nr.) must be completed with sealing material, coil and supply voltage.

** Ex-coils may be used up to 80°C fluid temperature only. Higher pressure with Ex-coils are possible on request.

*** direct-current-coil CWMA conforms to temperature class T4(T130°C), alternating-current-coil conforms to temperature class T5(T95°C) by dust atmosphere
Cable cross section up to 1mm²

sealing material	Code	fluid temperature	applicable for	standard voltage	Code
NBR (Perbunan)	B	max. 80°C	neutral gases and liquids	24V = DC	02400
EPDM	E	max. 130°C	hot water, steam, not for oil and grease	24V ~ (50Hz)	02450
FPM	V	max. 130°C	oil, petrol, oxygen	230V ~ (50Hz)	23050

coil power consumption at 20 °C, protection class, interface					
coil type	inrush power ~ (50Hz) VA	rated power ~ (50Hz) VA	power = (DC) (W)	protection class with/without connector	interface
C2DA	13	10	6,5	IP65 / IP00	Connector (DIN 43650) type B industrial standard
C3AA	17	13	6,3	IP65 / IP00	DIN EN 175301-803 A
CWMA *	3,2 class T5	3,2 class T5	3,8 class T4	IP66	Ex db mb IIC T4 Gb EX tb IIIC Tx°C Db IP66 Db*** coil with cable terminal box

* direct-current-coil CWMA conforms to temperature class T4(T130°C), alternating-current-coil conforms to temperature class T5(T95°C) by dust atmosphere
Cable cross section up to 1mm²

ORDER CODE	62 B - 9 B F - A C3AA 23050				
	type	function	ports	seal material	supply voltage
type	type 62				
function	A = normally closed, B = normally open				
ports	4 = G1/2, 5 = G3/4, 6 = G1, 7 = G1 1/4, 8 = G1 1/2, 9 = G2				
seal material	B = NBR (Perbunan), E = EPDM, V = FPM				
throw off spring	only by type 62B,				
short circuit ring	A = copper short circuit ring, X = without short circuit ring				
coil type	see specifications of the particular coil				
supply voltage	always 5-digit, see code of standard voltage				

for type 62A a bistable manual override is optional available. If needed please write into plaintext.

2/2 way solenoid valve normally closed or normally open

type 62, body stainless steel 1.4301 (AISI304)

pilot operated, DN 13-50mm, G1/2 – G2

type 62B, normally open					
type * (order-nr.)	NW DN (mm)	ports	maximum differential pressure in bar **		kv-value (m ³ /h)
			coil C2DA		
			AC and DC	coil CWMA *** AC and DC	
62B – 4.C – AC...	13	G1/2	0,3 – 8	0,3 – 8	3,4
62B – 5.C – AC...	19	G3/4			4,8
62B – 6.C – AC...	24	G1			8,5
62B – 7.C – AC...	30	G 1 1/4	0,3 – 5	0,3 – 5	15
62B – 8.C – AC...	38	G 1 1/2			19,5
62B – 9.C – AC...	48	G 2			30,5
type * (order-nr.)	NW DN (mm)	ports	maximum differential pressure in bar **		kv-value (m ³ /h)
			coil C3AA		
			AC and DC		
62B – 4.F – AC...	13	G1/2	0,3 – 16		3,4
62B – 5.F – AC...	19	G3/4			4,8
62B – 6.F – AC...	24	G1			8,5
62B – 7.F – AC...	30	G 1 1/4	0,3 – 8		15
62B – 8.F – AC...	38	G 1 1/2			19,5
62B – 9.F – AC...	48	G 2			30,5

* Type designation (order-nr.) must be completed with sealing material, coil and supply voltage.

** Ex-coils may be used up to 80°C fluid temperature only. Higher pressure with Ex-coils are possible on request.

*** direct-current-coil CWMA conforms to temperature class T4(T130°C), alternating-current-coil conforms to temperature class T5(T95°C) by dust atmosphere
Cable cross section up to 1mm²

2/2 way solenoid valve normally closed or normally open

type 62, body stainless steel 1.4301 (AISI304)

pilot operated, DN 13-50mm, G1/2 – G2

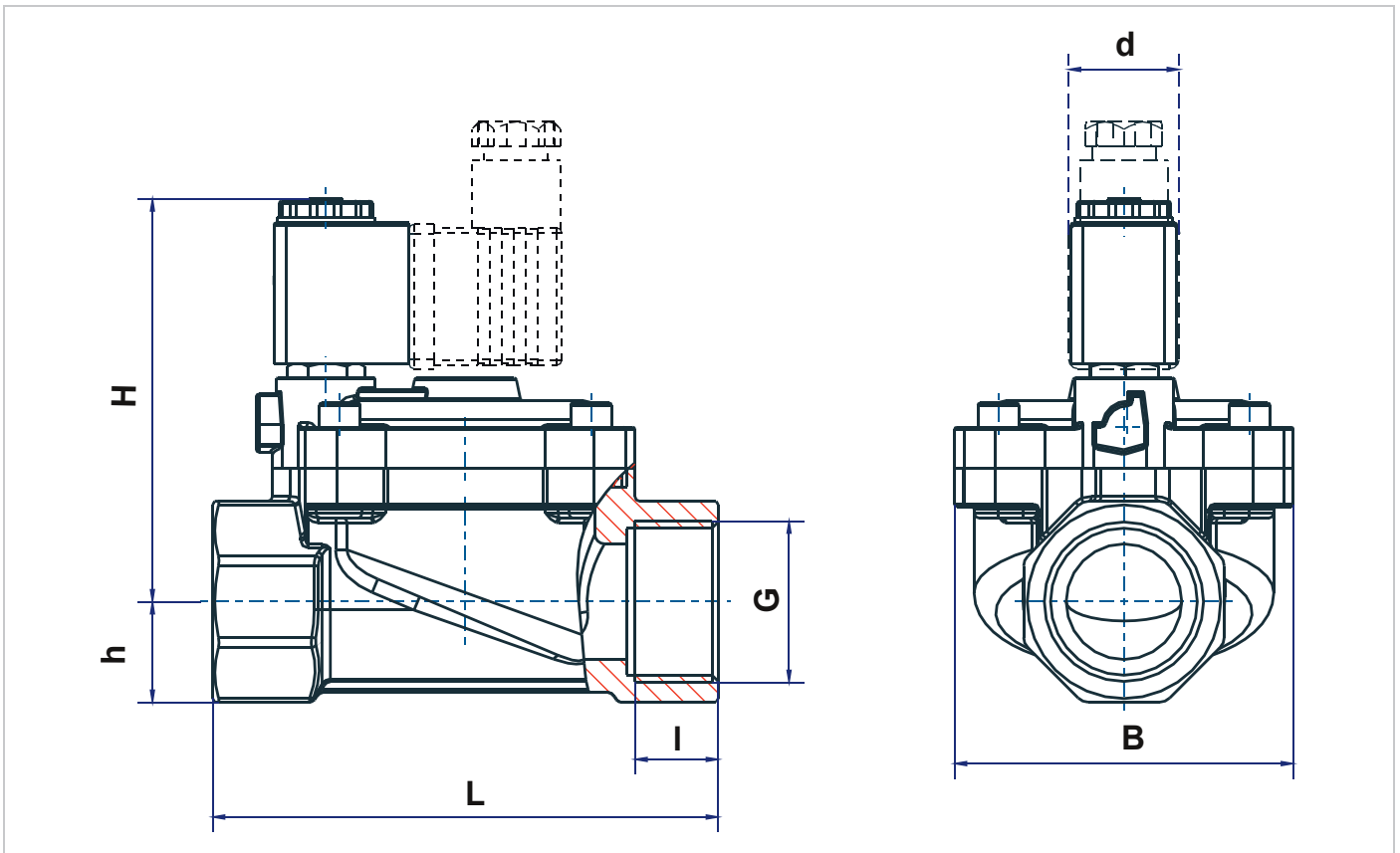

dimension table for type 62 in mm

Typ	B	d			G	h	H	I	L	weight * (approx. kg.)
		C2	C3	CW						
62. - 4. - AC...	42	22	30	36	G 1/2	10	78	14	66	0,4
62. - 5. - AC...	51				G 3/4	13	81	16	79	0,55
62. - 6. - AC...	71				G 1	16	90	17	105	1,11
62. - 7. - AC...	85				G 1 1/4	20	96	20	130	1,58
62. - 8. - AC...	96				G 1 1/2	23	106	20	146	2,22
62. - 9. - AC...	125				G 2	30	114	23	174	3,75

* Weight value refers to coil C2DA

Additional weight for C3AA = 0,06kg, for CWMA = 0,11kg