

2/2 way solenoid valve normally closed or normally open

type 70, body brass

force pilot operated, DN 16-50mm, G 3/8 – G 2



SPECIFICATION	
general	
type of construction	2/2-poppet valve, with diaphragm, normally closed NC or normally open NO, coil 360° rotatable
operator	solenoid
ports	G 3/8 – G 2
ambient temperature	-20 °C to +50 °C, higher allowed ambient temperatures on request
fluid temperature	dependent on sealing material and coil
viscosity	max. 21mm ² /s (cst) or 3°E
material	body brass, inner parts stainless steel and brass, sealing see type selection
mounting	installation into fixed piping system
installation	only with vertical fixed solenoid coil
unit of supply	without connector
electrical data	
voltage	DC voltage or AC voltage
standard voltage	24V DC, 24V AC, 230V AC
special voltage on request	6V-200V DC, 12V-240V, 50Hz or 60Hz
acceptable voltage tolerance	+/- 10%
power consumption	see specifications at solenoid coils
coil type	temperature class F (155°C), winding class H (180°C), coil E3 temperature class H
duty cycle	100% ED (DB), continuous operation
protection class	IP65 according DIN EN 60529 (DIN 40050) with correctly mounted connector
pneumatic – hydraulic	
flow medium	all liquids and gases, which don't attack the used material
max. body housing pressure	PN 16 (bar)
response time	depending on operating pressure and fluid
special equipment on request	coil type with cable, bright nickel-plated or chemical nickel-plated, coils for temperature class H (180°C)

2/2 way solenoid valve normally closed or normally open

type 70, body brass

force pilot operated, DN 16-50mm, G 3/8 – G 2

type 70A, normally closed							
type * (order-nr.)	NW DN (mm)	ports	maximum differential pressure in bar **				kv-value (m ³ /h)
			coil E1AA		coil E3AE		
			~ (50Hz)	= (DC)	~ (50Hz)	= (DC)	
70A-3.-A....	16	G3/8	0 – 10	0 – 14	0 – 7	0 – 14	3,5
70A-4.-A....	16	G1/2					3,8
70A-5.-A....	20	G3/4					4,7
70A-6.-A....	25	G1					8,0

type* (order-nr.)	NW DN (MM)	ports	maximum differential pressure in bar **				kv-value (m ³ /h)
			coil F1AA		coil G1AA		
			~ (50Hz)	= (DC)	= (DC)	~ (50Hz)	
70A-7.-A....	32	G1 1/4	0 – 12	0 – 3	0 – 9	0 – 10	13,0
70A-8.-A....	40	G1 1/2	0 – 10	0 – 2,5	0 – 7	0 – 10	16,8
70A-9.-A....	50	G2		0 – 1,5	0 – 5		30,2

* Type designation (order-nr.) must be completed with sealing material, coil and supply voltage (see order code).

** At DC voltage all pressure specifications apply to a fluid temperature up to 80 °C. At higher fluid temperatures, the maximum differential pressure will be reduced by 0,4% / °C.

sealing material	Code	fluid temperature	applicable for	standard voltage	Code
NBR (Perbunan)	B	max. 80°C	neutral gases and liquids	24V = DC	02400
EPDM	E	max. 130°C	hot water, steam, not for oil and grease	24V ~ (50Hz)	02450
FPM	V	max. 130°C	oil, petrol, oxygen	230V ~ (50Hz)	23050

coil power consumption at 20 °C, protection class, interface					
coil type	inrush power ~ (50Hz) VA	rated power ~ (50Hz) VA	power = (DC) (W)	protection class with/without connector	interface
E1AA	32	14	12	IP65 / IP00	EN 175301-803, type A (DIN 43650-A)
E3AE	70	32	27		
F1AA	70	35	27		
G1AA	80	40	32		

ORDER CODE	70 A - 6 B - A E3AE 02400	
	type function ports seal material	supply voltage coil type short circuit ring
type	type 70	
function	A = normally closed, B = normally open	
ports	3 = G 3/8, 4 = G 1/2, 5 = G 3/4, 6 = G 1, 7 = G 1 1/4, 8 = G 1 1/2, 9 = G 2	
seal material	B = NBR (Perbunan), E = EPDM, V = FPM	
short circuit ring	A = copper short circuit ring, X = without short circuit ring	
coil type	see specifications of the particular coil	
supply voltage	always 5-digit, see code of standard voltage	

2/2 way solenoid valve normally closed or normally open

type 70, body brass

force pilot operated, DN 16-50mm, G 3/8 – G 2

type 70B, normally open							
type * (order-nr.)	NW DN (mm)	connection	maximum differential pressure in bar **				kv-value (m ³ /h)
			coil E3AE		coil F1AA		
			~ (50Hz)	= (DC)	~ (50Hz)	= (DC)	
70B-3.-A....	16	G 3/8					3,5
70B-4.-A....	16	G 1/2	0 – 14	0 – 14	-	-	3,8
70B-5.-A....	20	G 3/4					4,7
70B-6.-A....	25	G 1	0 – 7	0 – 7	0 – 14	0 - 14	8,0

type* (order-nr.)	NW DN (MM)	connection	maximum differential pressure in bar **				kv-value (m ³ /h)
			coil F1AA				
			~ (50Hz)	= (DC)			
70B-7.-A....	32	G 1 1/4					13
70B-8.-A....	40	G 1 1/2	0 – 10	0 – 10			16,8
70B-9.-A....	50	G 2					30,2

* Type designation (order-nr.) must be completed with sealing material, coil and supply voltage (see order code).

2/2 way solenoid valve normally closed or normally open

type 70, body brass

force pilot operated, DN 16-50mm, G 3/8 – G 2

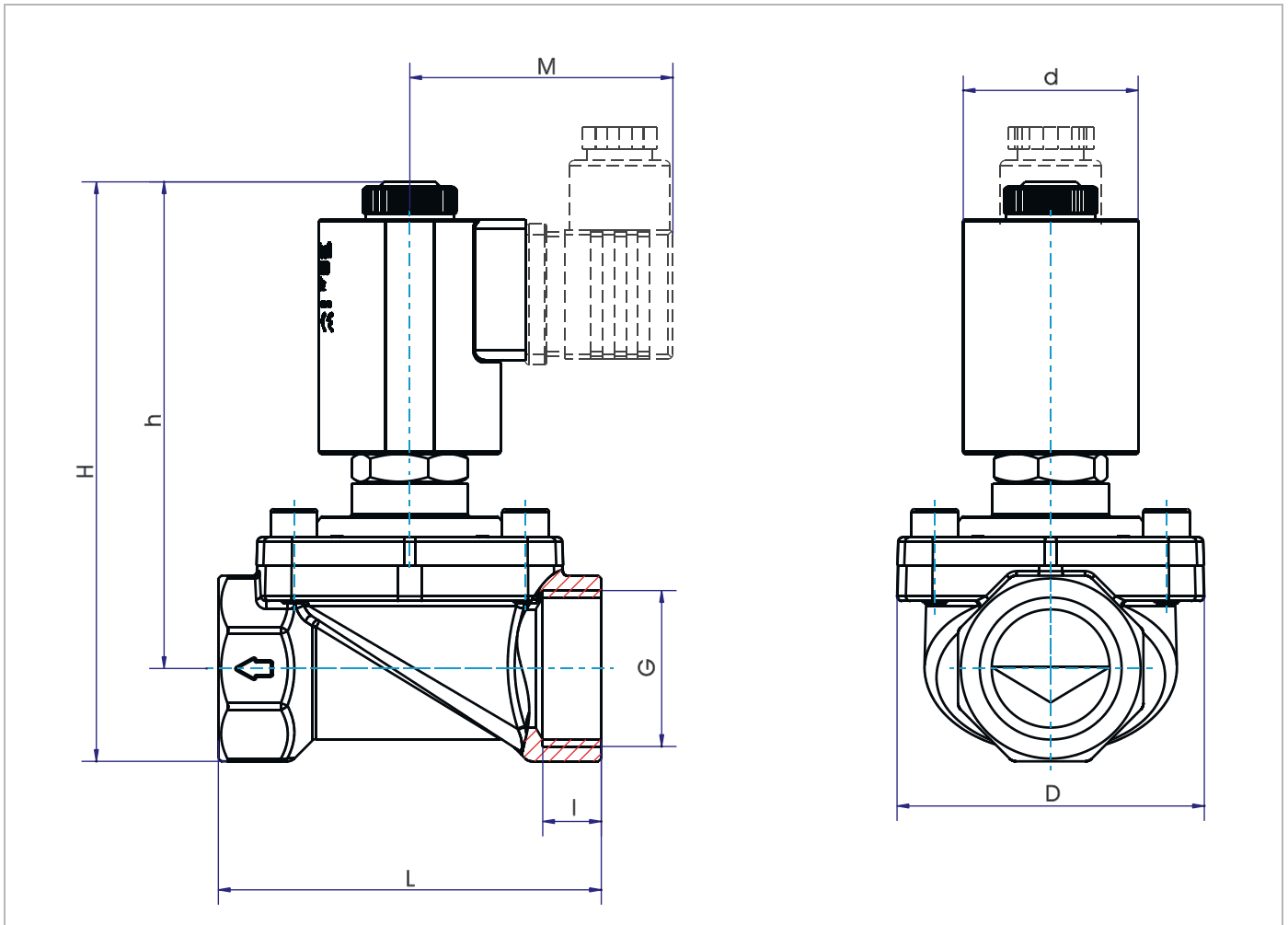

Dimension table for type 70 in mm, weight approx. kg

G	coil	type 70A-		type 70B-		M	d	L	I	D	weight approx. kg	
		H	h	H	h						70A-	70B-
G 3/8	E1	101	87.5	118	105	52.5	30	60	12	45	0,53	0,62
	E3					54	36				0,61	0,70
	F1					55	39				0,68	0,80
G 1/2	E1	101	87.5	118	105	52.5	30	62	11	50	0,50	0,59
	E3					54	36				0,58	0,67
	F1					55	39				0,65	0,77
G 3/4	E1	106	90	123.5	107.5	52.5	30	82	18	65	0,56	0,65
	E3					54	36				0,64	0,73
	F1					55	39				0,71	0,83
G1	E1	115	95	132	112	52.5	30	110	22	85	0,83	0,92
	E3					54	36				0,91	1,00
	F1					55	39				0,98	1,10
G1 1/4	F1	137	111.5	155.5	131	55	39	133.5	18	82	1,52	1,64
	G1	149	124	169.5	144.5	61	46				1,75	1,84
G1 1/2	F1	142.5	114.5	161.5	133.5	55	39	133.5	22	85	1,74	1,86
	G1	155	127	175.5	147.5	61	46				1,97	2,06
G2	F1	157	123	176	142	55	39	133.5	22	107	2,77	2,89
	G1	169	135	190	156	61	46				3,00	3,09